

PS-1

בקר תאורה כיוון פנימי 30-930 LUX

The PS-1 monitors outside light fixtures according to daylight, this includes Playgrounds, offices, schoolyards, garage, stores exhibit windows etc'. It switches on when it getting dark and switch off as soon as day goes on even if weather is cloudy during day time. The electronic device built inside robust waterproof case for outdoor install. Device Adjustment: brightens value can be adjusted between 30 to 930 Lux. Adjustment is done directly on the PS board as it shown on the diagram. By turning the adjustment knob to (D) position "dark state" the relay will energize as soon as it will start darken outside. Turning the knob to (L) position "light state" the relay will energize in brighter illumination. In order to prevent random switching the PS has internal delay of 20 sec. This prevents momentary light flashes such as car dazzle or short dark periods appearance, usually caused by cloudy days etc'.



General specifications

- Power supply: refer to table (ordering information)
- Supply tolerance: +10% / -15%
- Frequency: 50 / 60Hz
- Power consumption: 1 VA
- Duty cycle: 100%
- Protection class open air: IP20
- Protection class enclosed: IP40
- Protection class box: IP 66
- Self-extinguishing plastic housing UL V0 acc IEC 529
- Protection class light sensor: IP65
- Cable length to sensor max: 100 M
- Switching delay built in: 20s
- Switching status indication: yes
- Terminal : acc IEC 60947-7-1, IEC 60998-1
- Terminal Capacity: 1x4mm² without multicore cable end
 1x0.5 to 2.5mm² with/without multicore cable end

Dimensions & weight

- Width: 111(4.40") mm
- Height: 111(4.40") mm
- Depth (excl. DIN-profile): 53 mm
- Weight: 170 gram

Connections

230VAC / 110VAC

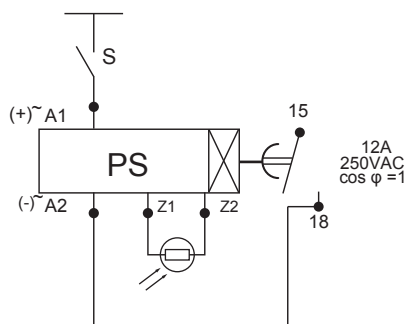

48VDC / 24VDC

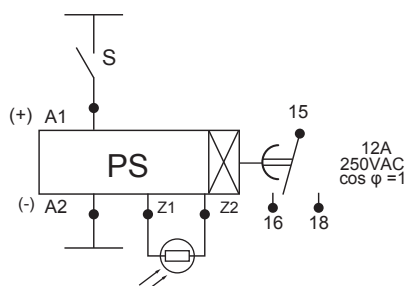

Output circuit

- Relay: 1 N/O
- Rated voltage: 250 Vac
- Switching capacity ac: 2000 VA (8A / 250V) COSφ=1
- Switching capacity dc: 3 A 30 Vdc
- Max switching capacity ac: 12 A
- Mechanical life: 1 x 10⁶ operations
- Electrical life at 1000 VA COS φ=1: 200.000 operations

Accuracy

- Base accuracy at min. and max scale: ±1%
- Adjusting accuracy: <5% of max scale value
- Repetition accuracy under constant condition: <0.5% (as % of full range)
- Voltage influence: No
- Temperature influence: < 0.01% / °C

Environmental conditions

- Permissible ambient temperature: -20°C....+50°C
- Storage temperature: -25°C....+70°C
- Transport temperature: -25°C....+70°C
- Relative humidity (acc. IEC 721-3-3 CLASS 3K3): 15% to 85%
- Vibration resistance (acc. IEC 68-2-6): 10 TO 55 H
- Light sensor: -25°C....+70°C

Ordering information

PS — V

230VAC	
110VAC	
48VDC	
24VDC	

Dimensions

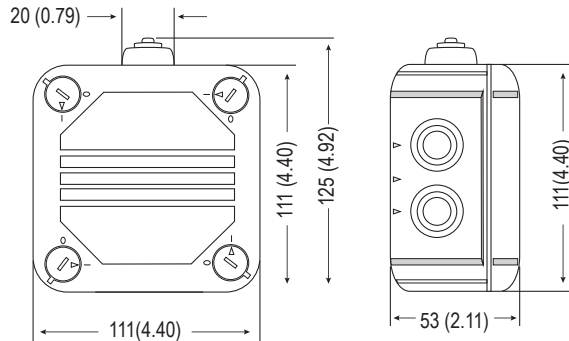

Installation Guide

Mounting on wall:

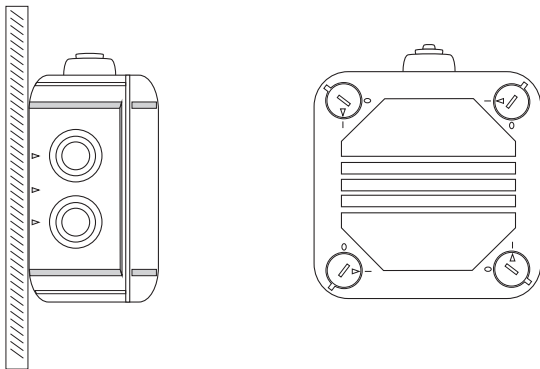

Wiring					
75°C Wire					
L1 - T1	[mm ²] 0.05 ± 4	[mm ²] 0.05 ± 4	N.A.		M3 0.5Nm
N, 1, 2, 3 W, X, (+) (-)	[mm ²] 0.05 - 4	[mm ²] 0.05 - 4	N.A.	N.A.	M3 0.5Nm Max

Important: When using electric or pneumatic tools for screw terminals observe max. torque limits

48VDC / 24VDC

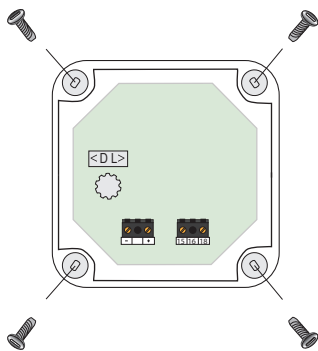

230VAC / 110VAC

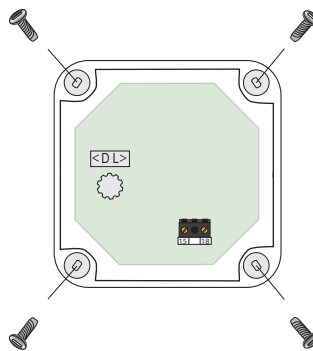

Precautions For Installation and Safe Use

Failure to follow those instructions will result in death or serious injury.

- Disconnect all power before working on equipment.
- Do not try to clean the device with solvent or the like. Only clean the device with a dried cloth.
- Verify correct terminal connections when wiring.
- To connect the unit, use appropriate insulated 230VAC cord.
- Electrical equipment should be serviced only by your competent seller.

No responsibility is assured by the manufacturer or any of its subsidiaries for any consequences arising out of the use of this material.